

TOP PRODUCTS AND SERVICES FOR **STERILIZATION**

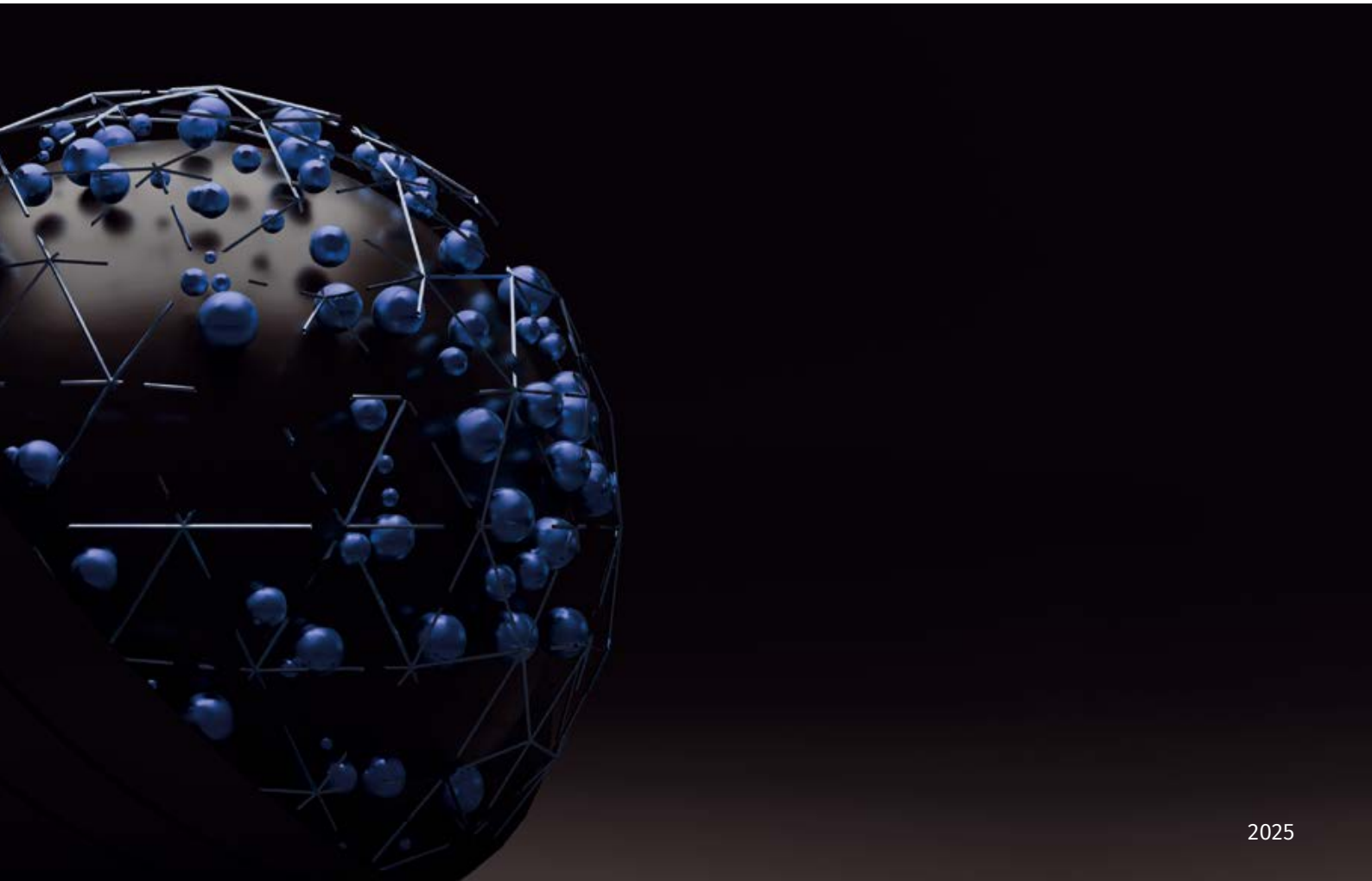

Our product range includes a wide selection of high-quality equipment and systems that meet the highest standards of reliability, precision and safety. Whether you run a small laboratory or are part of a large research team, you will find the right solutions to meet your requirements.

We are specialists in steam sterilizers, which we have been developing and producing ourselves for over 50 years under the brand name VARIOKLAV®. These devices meet the highest requirements for the sterilization of laboratory materials and are available in various sizes and designs.

Our products are characterised by the highest quality and effectiveness and help to ensure that your laboratory can work safely and hygienically.

Of course, we also offer comprehensive maintenance and service for all types of equipment to ensure that your equipment is always in perfect condition and is available to you reliably and for the long term. A comprehensive range of accessories and consumables completes our offering.

We are proud to offer you top products and services for laboratory hygiene, safety, sterilization and disinfection.

Our team of experienced professionals is available to assist you in choosing the right equipment and to help you with any questions or problems you may have.

We thank you for your interest in our products and look forward to providing you with high quality solutions for your laboratory needs.



Dr. Helmut Herz
Managing director

HP TECHNOLOGY GROUP

The companies of the HP TECHNOLOGY GROUP develop and produce medical devices and laboratory technology for microbiological laboratories, food manufacturers, pharmaceutical companies, research institutes and educational institutions or military organisations.

The group of companies bundles experience and competence and offers complete solutions at the highest quality level. Thanks to knowledge exchange and technology transfer, VARIOKLAV sterilizers are among the best-selling sterilizers in Germany and the AEMP systems are unique worldwide.

HP TECHNOLOGY GROUP



Page	Content
4	HP Labortechnik
4	Basics of steam sterilization
6	VARIOKLAV BlueLine
6	BlueLine
8	BlueLine Module
10	BlueLine 75 S 100 S
12	BlueLine 135 S 155 S 175 S
14	BlueLine 75 T 100 T
16	BlueLine 135 T 155 T 175 T 195 T
18	BlueLine 65 T
19	MedLine 65 TC
19	BlueLine 25 TV
20	VARIOKLAV BlueLine LC
20	BlueLine 75 S LC 135 S LC 155 S LC
22	VARIOKLAV GreenLine
24	GreenLine 80 S
25	GreenLine 140 S 160 S 180 S
26	GreenLine 80 T
27	GreenLine 140 T 160 T 180 T
28	VARIOKLAV OrangeLine
28	OrangeLine 95 S
30	VARIOKLAV
30	Technical data
32	Loading capacities
34	Accessories
36	Consumables
38	VARIOKLAV Support
39	HP Academy - education, training and certificate courses
40	HP Quality
441	Delivery and initial operation
42	Device configuration
44	Contact



Experience since 1979



Quality Made in Germany



Sustainable

BASICS OF STEAM STERILIZATION

GENERAL TERMS

CONTAMINATION:
Products or items that are not sterile

DISINFECT:
Killing pathogens

STERILIZATION:
Complete sterilization, killing of micro-organisms including their dormant state

INACTIVATION:
Complete destruction of the biological activities of microorganisms (microbiological entity capable of reproducing or transferring genetic material).

STEAM STERILIZATION:
Steam sterilization is a very effective, environmentally friendly method that can be used for almost all goods to kill microorganisms using steam above atmospheric pressure. Usually, a temperature of 121 °C is used with an exposure time of 20 minutes. Very dangerous or thermoresistant germs are killed at 134 °C and an exposure time of 15 minutes.



PROCEEDINGS

AUTOCLAVE:
Apparatus in which materials, utensils and equipment are exposed to steam above atmospheric pressure and thereby sterilized.

GRAVITY PROCESS:
The air in the sterilization chamber is displaced by the incoming steam downwards out of the chamber via a valve, generally in the liquid programme.

PRESSURE CHANGE METHOD:
The sterilization chamber is filled with steam several times until the specified operating pressure is reached, on standard models in the instruments / waste programme.

VACUUM METHOD:
The sterilization chamber is evacuated and filled with steam until the working pressure is reached.

VACUUM WITH DRYING:
The sterilization chamber is evacuated and heat is supplied via the chamber jacket at the same time.

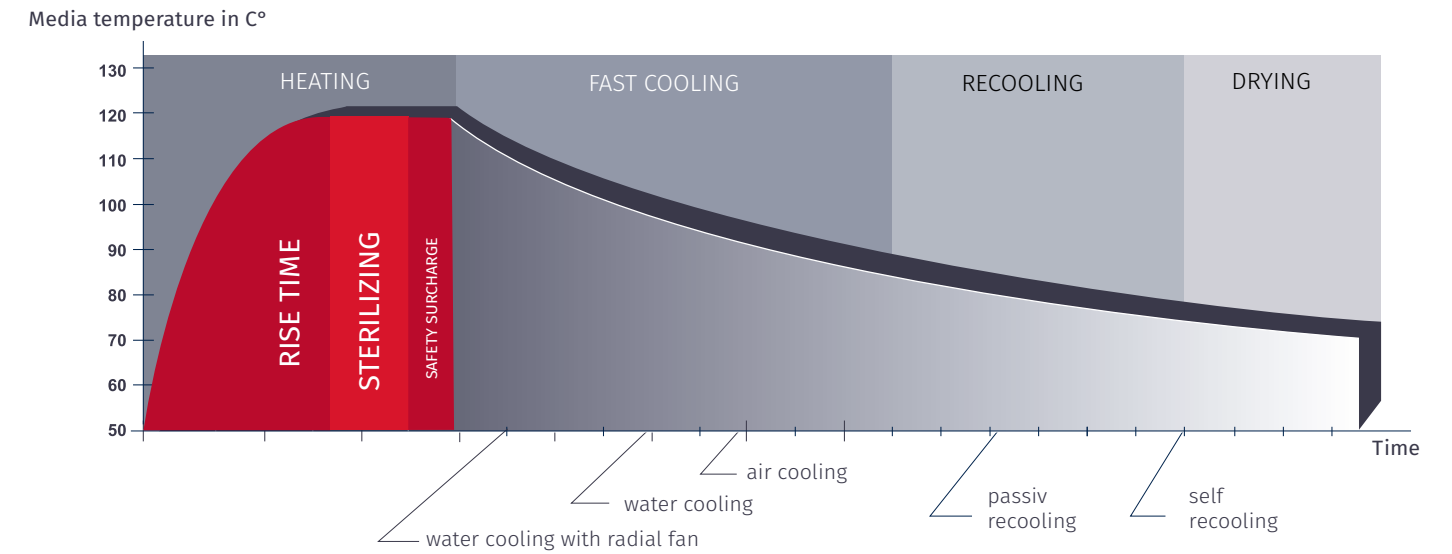

PROGRAMMES

LIQUIDS I
For liquid laboratory waste, forced cooling

LIQUIDS II
Low-loss, for larger liquid volumes

INSTRUMENTS
For instruments, glass, devices

WASTE
For mixed loads, laboratory waste with low liquid content

EMPTYING PROGRAMME
For cleaning the steam generator (BlueLine only)

PREHEATING PROGRAMME
for constant operational readiness (BlueLine only)



AREAS OF APPLICATION

MICROBIOLOGY LABORATORY:
Sterilization of liquids
Production of culture media
Sterilization of infectious laboratory waste
Sterilization of genetically modified substances

PRODUCTION
Production of sterile medical and pharmaceutical products

INDUSTRY
Pressurised climate chamber for long-term tests

●● Made in Germany

VARIOKLAV®
EXCELLENCE IN AUTOCLAVES

BlueLine

Powerful autoclaves for laboratories, medical practices and clinics

The VARIOKLAV® BlueLine offers high-quality Steam sterilizers that are ideally equipped for all routine tasks in a microbiology laboratory: Autoclaving liquids, solids or culture media safely, precisely, validatably and reproducibly. Our Steam sterilizers work quickly and reliably and offer plenty of space for instruments and bulky sterilization items.

Free-standing units

Our solid VARIOKLAV® floor-standing units offer the largest possible usable volume with the smallest footprint. The low working height allows the user to load and unload the autoclave comfortably from above.

The separate steam generator prevents contamination of the feed water by condensate, waste or media. The sterilization chamber is therefore free of heating elements and feed water.

The compressed air supply for the seal control circuit, safety interlock and pneumatic control valves is completely self-sufficient.

All advantages at a glance

- Separate steam generation
- Thermal barrier for liquids
- Self-sufficient compressed air supply
- Low feed water consumption despite high flow rate
- Easy-to-clean sterilization chamber without internal heating elements and feed water
- Slim design
- Can optionally be equipped with lift, vacuum, cooling, drying, filtration, documentation and media temperature control modules
- All components of our sterilizers are optimised for the longest possible durability

Table-top devices

VARIOKLAV® table-top autoclaves impress with their outstanding capacity on a very small footprint: Our compact table-top autoclaves are equipped with space-saving swing doors. Thanks to the particularly space-saving design, there are neither heating elements nor feed water inside the chamber, which makes cleaning the chamber particularly easy.

The table-top autoclave can be installed at almost any height allowing comfortable loading and unloading of the chamber at any height, and unloading of the chamber is possible at any height.



VARIOKLAV®
EXCELLENCE IN AUTOCLAVES

Floor-standing units with capacities from 75 to 175 litres
Table-top units with capacities from 25 to 195 litres

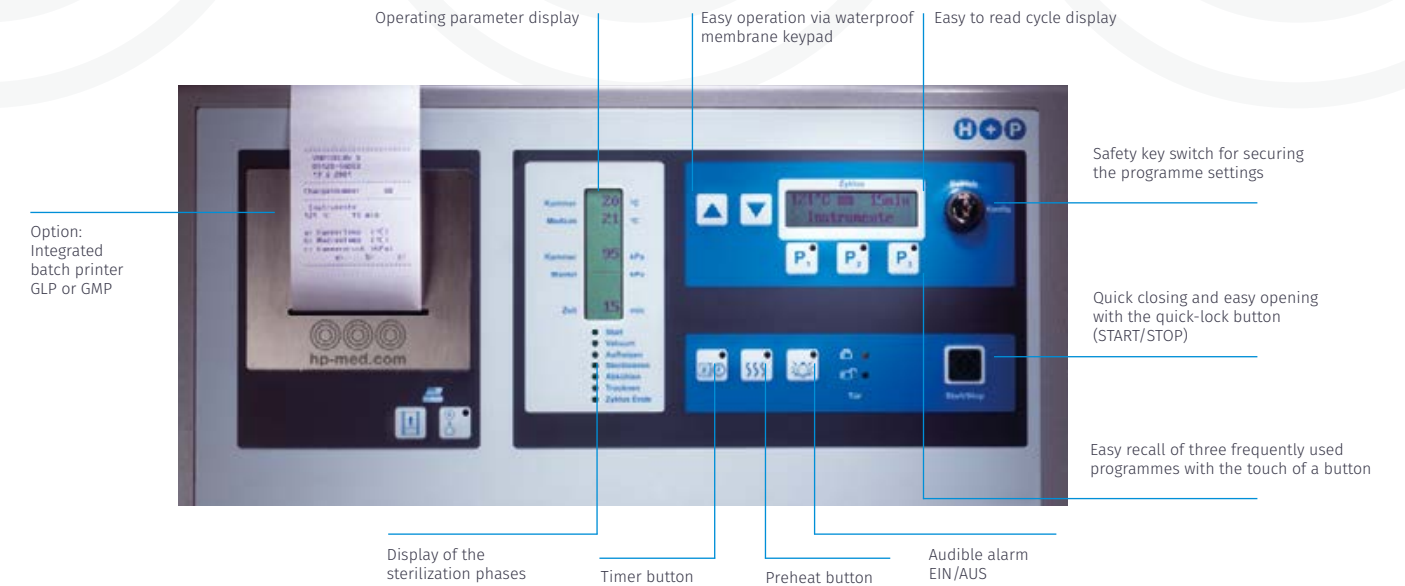

Touch-display control unit

Operation via the new touch display is intuitive and convenient. Clear and simple icons, pre-configured sterilization programmes or individually adapted programme sequences enable a validated sterilization process.

- Retrofittable for existing devices
- Control unit with 7" capacitive touch display (works with gloves)
- 16 GB internal memory (up to 100.000 logs)
- Controllable via mobile phone
- GxP/FDA 21 CFR Part 11 compliance, audit trail
- All standard programs preinstalled incl. F0 value calculation
- Multi-level user administration/ active directory function
- USB, WIFI, Bluetooth, LAN, 3G/4G connectivity, RFID chip card
- External server backups (reports on server FDA compliant)

NEW
TOUCH DISPLAY CONTROL UNIT
NEW

Module options

The BlueLine autoclaves can be equipped with numerous module options. Choose between modules for recooling and rapid recooling, vacuum and vacuum drying, emission-free sterilization, process documentation and media temperature and media temperature control to adapt your autoclave optimally to your routine work.

VARIOKLAV MODULES



Modules

The modular design of our Steam sterilizers also offers you the option of equipping your unit individually for a wide range of requirements.

Media temperature control

Media temperature control

No overheating, higher media quality, exact sterilization.

The media temperature is controlled via a flexible temperature sensor, directly in the reference vessel. This module option thus guarantees efficient and precise autoclaving by automatically triggering the sterilization time via the media temperature.



Media temperature control MT

Temperature-controlled high-precision sterilization

- Flexible temperature sensor directly in reference vessel ensures precise, temperature-controlled sterilization
- Set temperature is reliably reached
- Rapid cooling integrated in the RM and RG cooling module

Recooling for liquids

Fast cooling

Sterilization of liquids and culture media with high throughput

The cooling modules significantly reduce the cooling time of the autoclaves. This enables a higher throughput in batch processing. Depending on the process and loading of the autoclave, cooling times between 5 and 80 minutes are achieved.

RM cooling module for fast cooling

For sterilization of liquids in open vessels

- Stainless steel water cooling jacket integrated in sterilization chamber without limiting the loading capacity of the autoclave
- Variable function for heating, cooling and temperature control
- Media temperature control MT incl. media temperature sensor
- Up to 40% shorter cooling time
- Advantageous for thermolabile culture media, adjustable removal temperature, sterile ventilation

RG cooling module for rapid cooling

For liquids in open and pressure-tight sealed vessels

- RM cooling module - extended by a powerful radial blower and support pressure system with sterile compressed air
- Ideal for temperature-sensitive media

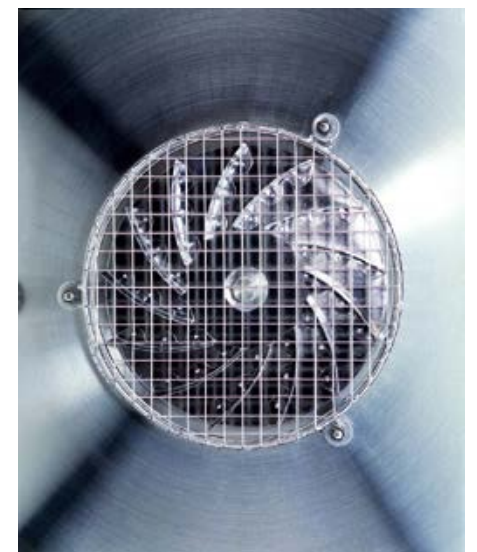

Documentation

Traceability of the sterilization process

Integrated printers and the SegoSof® software log the compliant documentation the sterilization process parameters of the autoclaves.

Process documentation

GLP Batch Printer

Conformity through data recording of process data

- Documents batch no. with date, process steps, starting from start to stop, e.g. chamber temperature, chamber pressure and possible alarm messages, filter count
- Recommended for safety level 2

IMS GMP batch printer

For complete documentation of release information

- Like GLP printer with documentation of batch number, date and process steps
- In addition, temperature and pressure data from control-independent reference sensors calibrated to ISO 9000 are recorded and shown on the display
- Suitable for protection class 3

Emission-free sterilization

With condensate sterilization, for safe sterilization of hazardous substances

Exhaust air filtration with condensate sterilization enables safe, emission-free sterilization of hazardous biological materials and media, including pathogens, infectious material and genetically modified samples. The environment and the wastewater system are protected from contamination.

FA Module exhaust air filtration

For safe sterilization of hazardous substances

- Aerosols in the exhaust air are already retained by a filter during the heating phase
- Simultaneous sterilization of chamber contents, condensate and filter housing including filter
- Sterilization chamber and floor or rear wall are heated with steam from the outside on all sides
- Dead space-free drain valve in the chamber floor ensures contamination-free disposal of the condensate



Pre-vacuum and vacuum drying

Sterilization of waste, solids and porous materials

A pre-vacuum module for VARIOKLAV autoclaves ensures the safe sterilization of porous materials and items that are difficult to vent. An additional vacuum drying module enables the removal of dry, sterile-ventilated materials.

Pre-vacuum and vacuum drying

VF module fractionated pre-vacuum

For thorough air removal before sterilization

- Single pre-vacuum or fractionated pre-vacuum cycle for complete air removal. Improves steam penetration into porous materials and thus the quality of sterilization
- Adjustable vacuum depth and number of pressure cycles allow economical processes for complete steam penetration

VT module vacuum drying

Prevents contamination of the sterile material after the drying phase

- VF module extended by drying in pulsed deep vacuum with powerful steam heating integrated in the double jacket, eliminates residual moisture



Emission-free sterilization

Art.No.	VARIOKLAV BlueLine 75 S 100 S	
51024301	BlueLine 75 S	Steam sterilizer, floor standing - basic version, usable space 75 litres, (ØxL) 400x600 mm, 4,8 kW, 3N/400V/16A, separate steam generator, media temperature control with flexible temperature sensor, integrated ADI exhaust steam condenser, hot-dip galvanised and powder-coated cladding
51902900	BlueLine 100 S	Steam sterilizer, stand-alone basic version, usable space 100 litres, (ØxL) 400x800 mm, 4,8 kW, 3N/400V/16A, separate steam generator, media temperature control with flexible temperature sensor, integrated ADI exhaust steam condenser, hot-dip galvanised and powder-coated cladding

DEVICE OPTIONS		
51900825	Enclosure made of stainless steel	Autoclave enclosure made of stainless steel, finely polished, instead of powder coating
51900826	Validation port 6-fold	For up to 6 temperature sensors PT 100, conforming to standards
51900851	Set of castors with parking brake	Castors with parking brake, for portable installation of freestanding units, 1 kit = 4 pieces

MODULE OPTIONS		
51900818	MT module - media temperature control	Control via temperature of liquids or media, for retrofitting
51900801	RM module - fast cooling	Fast cooling for liquids in open vessels, direct jacket cooling with demineralised water, including MT module - media temperature control and sterile ventilation
51900803	RG module - fast cooling	Fast cooling for liquids in open vessels, including RM cooling module, additionally with sterile support pressure and radial fan for steam circulation, external compressed air connection required
51900805	VF module - fractionated pre-vacuum	For hard-to-vent solid and porous materials in particular hollow bodies and trash in bags, including program for simple pre-vacuum
51900807	VT module - vacuum drying	Including VF module, post-drying with vacuum, double jacket steam-heated, for all solid and porous materials, including sterile ventilation, recommended drying time 15 to 60 min
51900809	FA module - exhaust air filtration	Air filtration with condensate sterilization, for all contaminated sterile goods, recommended for security level L1 (S1), required from security level L2 (S2) by surveillance authority
51900810	GLP batch printer	Integrated, for direct documentation of chamber and media temperature as well as chamber pressure
51900811	GMP batch printer	Integrated, for independent documentation of chamber temperature, media temperature and chamber pressure as well as separate process documentation via double sensors, including calibration certificates according to ISO 9000, GMP compliant
51900827	Sterile air ventilation	Sterile ventilation of the chamber at the end of the sterilization process

Art.No.	VARIOKLAV BlueLine 75 S 100 S	
SPECIAL PROGRAMS		
51900812	Steam pot program	Including media temperature control
51900813	Durham tube program	Bouillon program, possible from RM module
51900815	Sterilization temperature increase	Sterilization temperature increase to 140°C in saturated steam, for all programs, to 140°C adjustable setpoint

ACCESSORIES		
50095875	Lifting hoist	For easy loading and unloading, powder-coated, stroke 900 mm, load capacity 40 kg
50097753	Lifting hoist	For easy loading and unloading, stainless steel, stroke 900 mm, load capacity 40 kg
50091747	Wire basket round	(ØxH) 385x260 mm, stackable, max. 2 baskets per device possible
50110034	Wire basket round	(ØxH) 385x248 mm, stackable, max. 2 baskets per device possible, special size
50091196	Wire basket round, with drip tray	(ØxH) 385x260 mm, stackable, tray height 50 mm, max. 2 baskets per device possible
50092106	Metal bucket round	(ØxH) 390x280 mm, stackable, max. 2 buckets per device
50095759	Metal bucket round, with rotating lid	(ØxH) 390x280 mm, not stackable, max. 1 bucket per device
50094348	Desalination cartridge	For water desalination, type 2800, with conductivity meter and hose set
50094349	Desalination cartridge	For water desalination, type 2800, replacement cartridge for alternating operation
50085029	Aquastop	Aquastop, for up to 3 water supply lines leading, completely ready, continuous operation
50107364	Magnetic stirrer	Magnetic stirrer with one stirring point, including stirring bar and external control unit, pressure-tight encapsulated, integrated in the sterilizer, max. 40 litres stirring volume
607430	SegoSoft, SegoSerial module	Digital cycle and process documentation, software and SegoSerial module, RS-232/USB-interface, digital signature according to signature law, incl. cable 3 m
609496	SegoSoft, SegoConnect module	Digital cycle and process documentation, software and SegoConnect module, RS-232/ethernet-interface, digital signature according to signature law, incl. cable 3 m
609592	SegoSoft, FDA - CFR Part 11	Digital cycle and process documentation FDA conform, software and SegoConnect module, RS-232/ethernet-interface, digital signature according to signature law, incl. cable 3 m

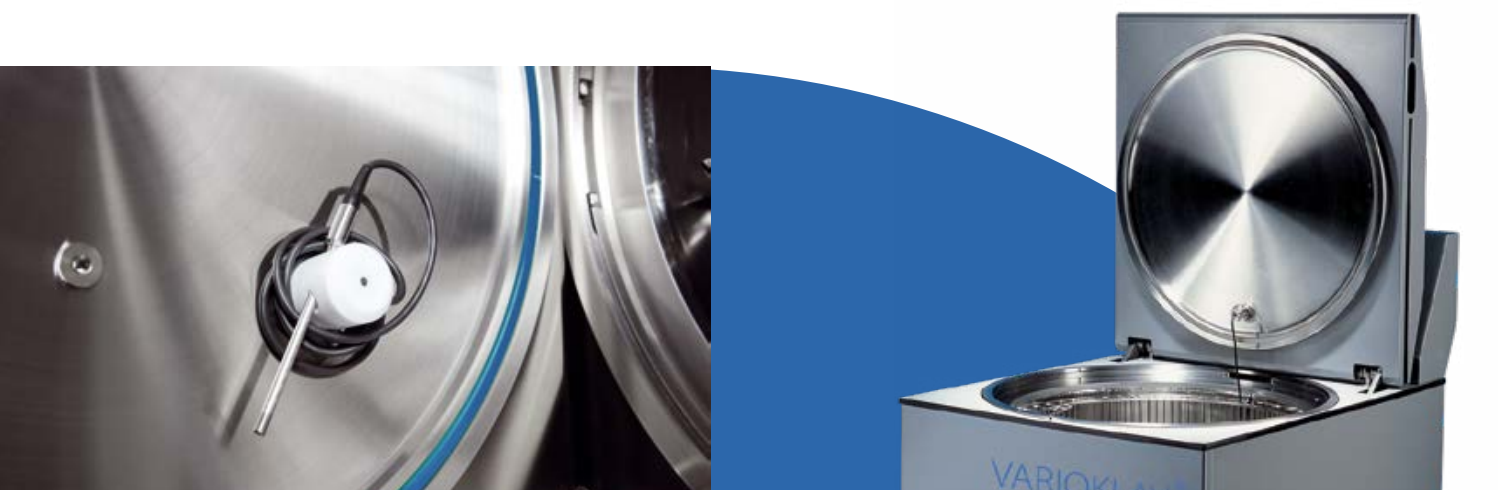

Art.No.	VARIOKLAV BlueLine 135 S 155 S 175 S	
51024302	BlueLine 135 S	Steam sterilizer, floor standing - basic version, usable space 135 litres, (ØxL) 500x700 mm, 7,8 kW, 3N/400V/16A, separate steam generator, media temperature control with flexible temperature sensor, integrated ADI exhaust steam condenser, hot-dip galvanised and powder-coated cladding
51902901	BlueLine 155 S	Steam sterilizer, floor standing - basic version, usable space 155 litres, (ØxL) 500x800 mm, 7,8 kW, 3N/400V/16A, separate steam generator, media temperature control with flexible temperature sensor, integrated ADI exhaust steam condenser, hot-dip galvanised and powder-coated cladding
51902902	BlueLine 175 S	Steam sterilizer, floor standing - basic version, usable space 175 litres, (ØxL) 500x900 mm, 7,8 kW, 3N/400V/16A, separate steam generator, media temperature control with flexible temperature sensor, integrated ADI exhaust steam condenser, hot-dip galvanised and powder-coated cladding

DEVICE OPTIONS		
51900825	Enclosure made of stainless steel	Autoclave enclosure made of stainless steel, finely polished, instead of powder coating
51900826	Validation port 6-fold	For up to 6 temperature sensors PT 100, conforming to standards
51900851	Set of castors with parking brake	Castors with parking brake, for portable installation of freestanding units, 1 kit = 4 pieces

MODULE OPTIONS		
51900818	MT module - media temperature control	Control via temperature of liquids or media, for retrofitting
51900801	RM module - fast cooling	Fast cooling for liquids in open vessels, direct jacket cooling with demineralised water, including MT module - media temperature control and sterile ventilation
51900803	RG module - fast cooling	Fast cooling for liquids in open vessels, including RM cooling module, additionally with sterile support pressure and radial fan for steam circulation, external compressed air connection required
51900805	VF module - fractionated pre-vacuum	For hard-to-vent solid and porous materials in particular hollow bodies and trash in bags, including program for simple pre-vacuum
51900807	VT module - vacuum drying	Including VF module, post-drying with vacuum, double jacket steam-heated, for all solid and porous materials, including sterile ventilation, recommended drying time 15 to 60 min
51900809	FA module - exhaust air filtration	Air filtration with condensate sterilization, for all contaminated sterile goods, recommended for security level L1 (S1), required from security level L2 (S2) by surveillance authority
51900810	GLP batch printer	Integrated, for direct documentation of chamber and media temperature as well as chamber pressure
51900811	GMP batch printer	Integrated, for independent documentation of chamber temperature, media temperature and chamber pressure as well as separate process documentation via double sensors, including calibration certificates according to ISO 9000, GMP compliant
51900827	Sterile air ventilation	Sterile ventilation of the chamber at the end of the sterilization process

Art.No.	VARIOKLAV BlueLine 135 S 155 S 175 S	
SPECIAL PROGRAMS		
51900812	Steam pot program	Including media temperature control
51900813	Durham tube program	Bouillon program, possible from RM module
51900815	Sterilization temperature increase	Sterilization temperature increase to 140°C in saturated steam, for all programs, to 140°C adjustable setpoint
606985	C-waste disinfection	certified procedure (RKI), required module options: VF + RG + FA + GMP, programs for c-waste solid and C-waste liquid

ACCESSORIES		
50095876	Lifting hoist	For easy loading and unloading, powder-coated, stroke 900 mm, load capacity 40 kg
50097752	Lifting hoist	For easy loading and unloading, stainless steel, stroke 900 mm, load capacity 40 kg
50091748	Wire basket round	(ØxH) 485x200 mm, stackable, max. 3 baskets per device
50099633	Wire basket round	(ØxH) 485x240 mm, stackable, max. 2 baskets per device possible, special size
50092114	Wire basket round	(ØxH) 485x320 mm, stackable, max. 2 baskets per device possible
50092112	Wire basket round, with drip tray round	(ØxH) 485x320 mm, stackable, tray height 50 mm, max. 2 baskets per device possible
50090683	Hanging tray for sterilization baskets	Ø 470 mm, including 4 mounting brackets for further loading level in the basket
50099824	Metal bucket round	(ØxH) 470x310 mm, stackable, max. 2 buckets per device
50095753	Metal bucket round, with rotating lid	(ØxH) 490x345 mm, not stackable, max. 1 bucket per device
50094348	Desalination cartridge	For water desalination, type 2800, with conductivity meter and hose set
50094349	Desalination cartridge	For water desalination, type 2800, replacement cartridge for alternating operation
50085029	Aquastop	Aquastop, for up to 3 water supply lines leading, completely ready, continuous operation
50107364	Magnetic stirrer	Magnetic stirrer with one stirring point, including stirring bar and external control unit, pressure-tight encapsulated, integrated in the sterilizer, max. 40 litres stirring volume
607430	SegoSoft, SegoSerial module	Digital cycle and process documentation, software and SegoSerial module, RS-232/USB-interface, digital signature according to signature law, incl. cable 3 m
609496	SegoSoft, SegoConnect module	Digital cycle and process documentation, software and SegoConnect module, RS-232/ethernet-interface, digital signature according to signature law, incl. cable 3 m
609592	SegoSoft, FDA - CFR Part 11	Digital cycle and process documentation FDA conform, software and SegoConnect module, RS-232/ethernet-interface, digital signature according to signature law, incl. cable 3 m



Art.No.	VARIOKLAV BlueLine 75 T 100 T	
51024303	BlueLine 75 T	Steam sterilizer, table-top unit - basic version, usable space 75 litres, (ØxL) 400x600 mm, 4,8 kW, 3N/400V/16A, separate steam generator, media temperature control with flexible temperature sensor, integrated ADI exhaust steam condenser, hot-dip galvanised and powder-coated cladding
51902903	BlueLine 100 T	Steam sterilizer, tabletop unit - basic version, usable space 100 litres, (ØxL) 400x800 mm, 4,8 kW, 3N/400V/16A, separate steam generator, media temperature control with flexible temperature sensor, integrated ADI exhaust steam condenser, hot-dip galvanised and powder-coated cladding

DEVICE OPTIONS		
51900825	Enclosure made of stainless steel	Autoclave enclosure made of stainless steel, finely polished, instead of powder coating
51900826	Validation port 6-fold	For up to 6 temperature sensors PT 100, conforming to standards

MODULE OPTIONS		
51900818	MT module - media temperature control	Control via temperature of liquids or media, for retrofitting
51900801	RM module - fast cooling	Fast cooling for liquids in open vessels, direct jacket cooling with demineralised water, including MT module - media temperature control and sterile ventilation
51900803	RG module - fast cooling	Fast cooling for liquids in open vessels, including RM cooling module, additionally with sterile support pressure and radial fan for steam circulation, external compressed air connection required
51900805	VF module - fractionated pre-vacuum	For hard-to-vent solid and porous materials in particular hollow bodies and trash in bags, including program for simple pre-vacuum
51900807	VT module - vacuum drying	Including VF module, post-drying with vacuum, double jacket steam-heated, for all solid and porous materials, including sterile ventilation, recommended drying time 15 to 60 min
51900809	FA module - exhaust air filtration	Air filtration with condensate sterilization, for all contaminated sterile goods, recommended for security level L1 (S1), required from security level L2 (S2) by surveillance authority
51900810	GLP batch printer	Integrated, for direct documentation of chamber and media temperature as well as chamber pressure
51900811	GMP batch printer	Integrated, for independent documentation of chamber temperature, media temperature and chamber pressure as well as separate process documentation via double sensors, including calibration certificates according to ISO 9000, GMP compliant
51900827	Sterile air ventilation	Sterile ventilation of the chamber at the end of the sterilization process



Art.No.	VARIOKLAV BlueLine 75 T 100 T	
SPECIAL PROGRAMS		
51900813	Durham tube program	Bouillon program, possible from RM module
51900815	Sterilization temperature increase	Sterilization temperature increase to 140°C in saturated steam, for all programs, to 140°C adjustable setpoint

ACCESSORIES		
50098202	Undercarriage for 75 T	(WxHxD) 532x805x708 mm, with additional shelf, extensible, 2 casters on the back, stainless steel, max. load capacity 300 kg
604791	Undercarriage for 100 T	(WxHxD) 532x805x908 mm, with additional shelf, extensible, 2 casters on the back, stainless steel, max. load capacity 300 kg
51900834	Center shelf	(WxHxD) 360x15x580 mm (WxHxD) 360x15x580 mm, stainless steel, loading level height adjustable in four positions
50101326	Wire basket cubic	(WxHxD) 300x120x535 mm, stackable, max. 2 buckets per device
50101323	Metal tub cubic	(WxHxD) 350x80x335 mm, stackable, 2 tubs per device
50094348	Desalination cartridge	For water desalination, type 2800, with conductivity meter and hose set
50094349	Desalination cartridge	For water desalination, type 2800, replacement cartridge for alternating operation
50085029	Aquastop	Aquastop, for up to 3 water supply lines leading, completely ready, continuous operation
50107364	Magnetic stirrer	Magnetic stirrer with one stirring point, including stirring bar and external control unit, pressure-tight encapsulated, integrated in the sterilizer, max. 40 litres stirring volume
607430	SegoSoft, SegoSerial module	Digital cycle and process documentation, software and SegoSerial module, RS-232/USB-interface, digital signature according to signature law, incl. cable 3 m
609496	SegoSoft, SegoConnect module	Digital cycle and process documentation, software and SegoConnect module, RS-232/ethernet-interface, digital signature according to signature law, incl. cable 3 m
609592	SegoSoft, FDA - CFR Part 11	Digital cycle and process documentation FDA conform, software and SegoConnect module, RS-232/ethernet-interface, digital signature according to signature law, incl. cable 3 m



Art.No.	VARIOKLAV BlueLine 135 T 155 T 175 T 195 T	
51024304	BlueLine 135 T	Steam sterilizer, tabletop unit - basic version, usable space 135 litres, (ØxL) 500x700 mm, 7,8 kW, 3N/400V/16A, separate steam generator, media temperature control with flexible temperature sensor, integrated ADI exhaust steam condenser, hot-dip galvanised and powder-coated cladding
51902904	BlueLine 155 T	Steam sterilizer, tabletop unit - basic version, usable space 155 litres, (ØxL) 500x800 mm, 7,8 kW, 3N/400V/16A, separate steam generator, media temperature control with flexible temperature sensor, integrated ADI exhaust steam condenser, hot-dip galvanised and powder-coated cladding
51902905	BlueLine 175 T	Steam sterilizer, tabletop unit - basic version, usable space 175 litres, (ØxL) 500x900 mm, 7,8 kW, 3N/400V/16A, separate steam generator, media temperature control with flexible temperature sensor, integrated ADI exhaust steam condenser, hot-dip galvanised and powder-coated cladding
51902906	BlueLine 195 T	Steam sterilizer, table-top unit - basic version, usable space 195 litres, (ØxL) 500x1,000 mm, 7,8 kW, 3N/400V/16A, separate steam generator, media temperature control with flexible temperature sensor, integrated ADI exhaust steam condenser, hot-dip galvanised and powder-coated cladding

DEVICE OPTIONS		
51900825	Enclosure made of stainless steel	Autoclave enclosure made of stainless steel, finely polished, instead of powder coating
51900826	Validation port 6-fold	For up to 6 temperature sensors PT 100, conforming to standards

MODULE OPTIONS		
51900818	MT module - media temperature control	Control via temperature of liquids or media, for retrofitting
51900801	RM module - fast cooling	Fast cooling for liquids in open vessels, direct jacket cooling with demineralised water, including MT module - media temperature control and sterile ventilation
51900803	RG module - fast cooling	Fast cooling for liquids in open vessels, including RM cooling module, additionally with sterile support pressure and radial fan for steam circulation, external compressed air connection required
51900805	VF module - fractionated pre-vacuum	For hard-to-vent solid and porous materials in particular hollow bodies and trash in bags, including program for simple pre-vacuum
51900807	VT module - vacuum drying	Including VF module, post-drying with vacuum, double jacket steam-heated, for all solid and porous materials, including sterile ventilation, recommended drying time 15 to 60 min
51900809	FA module - exhaust air filtration	Air filtration with condensate sterilization, for all contaminated sterile goods, recommended for security level L1 (S1), required from security level L2 (S2) by surveillance authority
51900810	GLP batch printer	Integrated, for direct documentation of chamber and media temperature as well as chamber pressure
51900811	GMP batch printer	Integrated, for independent documentation of chamber temperature, media temperature and chamber pressure as well as separate process documentation via double sensors, including calibration certificates according to ISO 9000, GMP compliant
51900827	Sterile air ventilation	Sterile ventilation of the chamber at the end of the sterilization process

Art.No.	VARIOKLAV BlueLine 135 T 155 T 175 T 195 T	
SPECIAL PROGRAMS		
51900813	Durham tube program	Bouillon program, possible from RM module
51900815	Sterilization temperature increase	Sterilization temperature increase to 140°C in saturated steam, for all programs, to 140°C adjustable setpoint

ACCESSORIES		
50098207	Undercarriage for 135 T	Stainless steel, (WxHxD) 632x800x788 mm, with additional shelf, 2 casters on the back, max. load capacity 300 kg
50101130	Undercarriage for 155 T	Stainless steel, (WxHxD) 632x800x888 mm, with additional shelf, 2 casters on the back, max. load capacity 300 kg
607134	Undercarriage for 175 T	Stainless steel, (WxHxD) 632x800x988 mm, with additional shelf, 2 casters on the back, max. load capacity 300 kg
607131	Undercarriage for 195 T	Stainless steel, (WxHxD) 632x800x1088 mm, with additional shelf, 2 casters on the back, max. load capacity 300 kg
51900835	Center shelf	(WxHxD) 460x15x645 mm 160x15x745 mm 460x15x845 mm 460x15x945 mm, loading level height adjustable in four positions, stainless steel
50101327	Wire basket cubic	(WxHxD) 345x170x335 mm, stackable, max. 4 baskets per device
50101325	Metal tub cubic	(WxHxD) 350x80x335 mm, stackable, 4 tubs per device
50094348	Desalination cartridge	For water desalination, type 2800, with conductivity meter and hose set
50094349	Desalination cartridge	For water desalination, type 2800, replacement cartridge for alternating operation
50085029	Aquastop	Aquastop, for up to 3 water supply lines leading, completely ready, continuous operation
50107364	Magnetic stirrer	Magnetic stirrer with one stirring point, including stirring bar and external control unit, pressure-tight encapsulated, integrated in the sterilizer, max. 40 litres stirring volume
607430	SegoSoft, SegoSerial module	Digital cycle and process documentation, software and SegoSerial module, RS-232/USB-interface, digital signature according to signature law, incl. cable 3 m
609496	SegoSoft, SegoConnect module	Digital cycle and process documentation, software and SegoConnect module, RS-232/ethernet-interface, digital signature according to signature law, incl. cable 3 m
609592	SegoSoft, FDA - CFR Part 11	Digital cycle and process documentation FDA conform, software and SegoConnect module, RS-232/ethernet-interface, digital signature according to signature law, incl. cable 3 m



Art.No.	VARIOKLAV BlueLine 65 T	
51024307	BlueLine 65 T	Steam sterilizer, tabletop unit - basic version, usable space 65 litres, (WxHxD) 330x330x630 mm, 9,3 kW, 3N/400V/16A, separate steam generator, media temperature control with flexible temperature sensor, hot-dip galvanised and powder-coated cladding, integrated ADI exhaust steam condenser

MODULE OPTIONS		
51900818	MT module - media temperature control	Control via temperature of liquids or media, for retrofitting
51900801	RM module - fast cooling	Fast cooling for liquids in open vessels, direct jacket cooling with demineralised water, including MT module - media temperature control and sterile ventilation
51900803	RG module - fast cooling	Fast cooling for liquids in open vessels, including RM cooling module, additionally with sterile support pressure and radial fan for steam circulation, external compressed air connection required
51900805	VF module - fractionated pre-vacuum	For hard-to-vent solid and porous materials in particular hollow bodies and trash in bags, including program for simple pre-vacuum
51900807	VT module - vacuum drying	Including VF module, post-drying with vacuum, double jacket steam-heated, for all solid and porous materials, including sterile ventilation, recommended drying time 15 to 60 min
51900809	FA module - exhaust air filtration	Air filtration with condensate sterilization, for all contaminated sterile goods, recommended for security level L1 (S1), required from security level L2 (S2) by surveillance authority
51900810	GLP batch printer	Integrated, for direct documentation of chamber and media temperature as well as chamber pressure
51900811	GMP batch printer	Integrated, for independent documentation of chamber temperature, media temperature and chamber pressure as well as separate process documentation via double sensors, including calibration certificates according to ISO 9000, GMP compliant
51900827	Sterile air ventilation	Sterile ventilation of the chamber at the end of the sterilization process
51900826	Validation port 6-fold	Port for up to 6 temperature sensors PT 100, conforming to standards

ACCESSORIES		
50085023	Undercarriage 65 T	With additional shelf, 2 castors on the rear side, stainless steel, max. load 300 kg
50085024	Center shelf	(WxHxD) 320x20x600 mm, loading level height adjustable in four positions
50101326	Wire basket cubic	(WxHxD) 300x120x535 mm, stackable, max. 2 baskets per device
50101323	Metal tub cubic	(WxHxD) 290x80x535 mm, stackable, max. 2 tubs per device
607430	SegoSoft, SegoSerial module	Digital cycle and process documentation, software and SegoSerial module, RS-232/USB-interface, digital signature according to signature law, incl. cable 3 m
609496	SegoSoft, SegoConnect module	Digital cycle and process documentation, software and SegoConnect module, RS-232/ethernet-interface, digital signature according to signature law, incl. cable 3 m
609592	SegoSoft FDA - CFR Part 11	Digital cycle and process documentation FDA conform, software and SegoConnect module, RS-232/ethernet-interface, digital signature according to signature law, incl. cable 3 m



Art.No.	VARIOKLAV BlueLine 25 TV	
609469	BlueLine 25 TV	Steam sterilizer, table-top unit, usable volume 25 litres, certified pre-owned, (ØxL) 255x490 mm, 3.3 kW, 230V/16A, powerful pre- and post-vacuum, GLP printer, flexible temperature sensor, incl. condensate collection container and trays
609776	BlueLine 25 TV FA	Steam sterilizer, table-top unit, usable volume 25 litres, certified pre-owned, (ØxL) 255x490 mm, 3.3 kW, 230V/16A, powerful pre- and post-vacuum, GLP printer, air filtration, flexible temperature sensor, incl. condensate collection container and trays, Safety level 2 capable



Art.No.	VARIOKLAV 65 TC	
51024308	VARIOKLAV MedLine 65 TC	Medical device 65 TC, tabletop model, 1 StE, complete, according to EN 285:2009, 65 litres chamber, (WxHxD) 330x330x630 mm, 9,3 kW, 3N/400V/16A, stainless steel cladding for instruments, textiles, hollow bodies and pharmaceutical products, GMP batch printer, VT modul, sterile air ventilation

BlueLine - Lite Complete.

All the advantages of the BlueLine in a new complete package!

The new, flexible Lite Complete product line offers flexible application options, it is location-independent and immediately ready for use thanks to the integrated supply of operating materials. Compact, space-saving steam sterilizers of 75, 135 or 155 liters, for fast and reliable sterilization of instruments, liquids and waste.

- completely ready for connection
- short delivery times
- low loading height
- space-saving design
- fast loading/unloading

All advantages at a glance

- free-standing units with 75, 135 and 155 liters capacity
- Sterilization chamber with steam generation in separate raised floor
- hot galvanized and powder coated cladding
- completely equipped and ready for operation with:
 - feed water tank
 - condensate collector
 - wire basket
 - wire basket with collecting tray
- standard programs for liquids, waste and instruments
- no on-site water connection required
- connection to VE water line possible
- exhaust air filtration available for the S2 laboratory

Art.No.	VARIOKLAV BlueLine 75 S LC 135 S LC 155 S LC	
51024305	BlueLine 75 S LC	Steam sterilizer, free-standing unit - basic version, usable volume 75 liters, (ØxL) 400x600 mm, 4,8 kW, 3N/400V/16A, separate steam generator, media temperature control with flexible temperature sensor, hot-dip galvanized and powder-coated cladding. Completely ready for connection with feed water tank, condensate collector, wire basket and wire basket with drip tray.
51902904	BlueLine 135 S LC	Steam sterilizer, free-standing unit - basic version, usable volume 135 Liter, (ØxL) 500x700 mm, 7,8 kW, 3N/400V/16A, separate steam generator, media temperature control with flexible temperature sensor, hot-dip galvanized and powder-coated cladding. Completely ready for connection with feed water tank, condensate collector, wire basket and wire basket with drip tray.
51902905	BlueLine 175 S LC	Steam sterilizer, free-standing unit - basic version, usable volume 155 Liter, (ØxL) 500x800 mm, 7,8 kW, 3N/400V/16A, separate steam generator, media temperature control with flexible temperature sensor, hot-dip galvanized and powder-coated cladding. Completely ready for connection with feed water tank, condensate collector, wire basket and wire basket with drip tray.

Completely ready for connection with feed water tank, condensate collector, wire basket and wire basket with drip tray.



- Media temperature control Included
- Condensate collector Included
- Feed water tank Included
- Wire basket Included
- Emission-free sterilization

Advantages

- Long service life due to low-wear fittings
- A large usable volume on a small footprint and a low overall height
- No on-site connections - except for power
- Problem-free installation and fast commissioning
- Simplest handling and operation
- Available module options such as cooling and exhaust air filtration with condensate sterilization

Safety

- All fittings are found inside the stainless steel cladding
- End plate made of heat-insulating plastic, no risk of injury from hot components
- Central lock with 6 massive locking levers, opening under pressure is completely impossible
- Lid can be opened laterally, no risk of scalding due to rising steam
- Floor-standing units heated from the outside.
- TÜV-approved overheating protection prevents overloading of the heating

Data recording

- As proof of a successfully completed sterilization process within the scope of quality assurance, the data of the sterilization process can be read out via a separate USB stick.

GreenLine

High quality technology

- 100% safety for germ destruction
- Pressurised containers, TÜV-tested, manufactured according to the Pressure Vessel Ordinance and other European regulations
- CE mark in accordance with the Low Voltage Directive
- Reverse rotation lock as a mechanically acting, safety against opening under pressure
- Additional pressure monitoring
- No double jacket, no vacuum
- No external steam generator
- For floor-standing appliance
- External contact heating elements



Flexible control unit

- Optimized deaeration process
- Exact set temperature control
- Separate control and safety circuit
- Temperature evaluation in three-wire technology
- Configuring, blocking and enabling sterilization programs
- Data recording via standard USB interface
- Media temperature controlled processes

Air jacket cooling

- Simple, inexpensive and effective recooling through air flow channels on the outside of the tank
- Cooling time shortened compared to self cooling: even with large vessels by at least 40%
- No additional on-site connections
- No cooling water required

Exhaust air filtration

- For safe and emission-free sterilization of contaminated, highly infectious or pathogenic materials and media, the exhaust air passed through a filter system.
- Any condensate is fed back into the sterilizer.
- The condensate and the filter system are autoclaved.

Sustainability

- Pressure vessel made of high-quality electropolished stainless steel, also long-lasting when handling aggressive media
- 5 years warranty on the pressure vessel
- Durable heating elements (3 years warranty)
- Very easy exchange of components
- Simple and cost-effective maintenance
- Low resource consumption
- Cardanic locking suspension, thus long durability of the seal
- Long service life due to low-wear fittings



VARIOKLAV MODULE

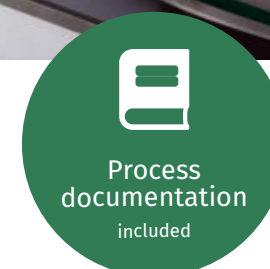
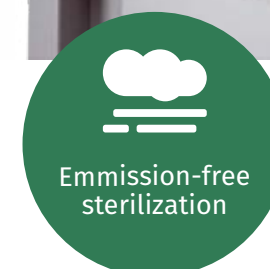
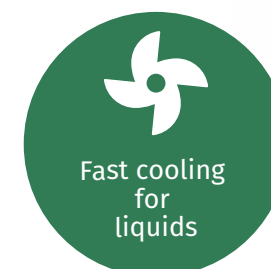
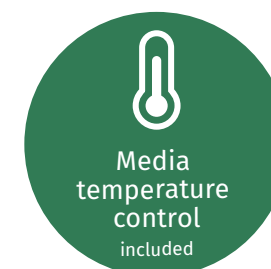

Art.No.	VARIOKLAV GreenLine 80 S	
608379	GreenLine 80 S	Steam sterilizer, floor model, basic unit, usable volume 80 litres, (ØxL) 400x600 mm, feed water volume 5 litres, MT module - media temperature control with flexible temperature probe, max. operating pressure -1 (vakuum fixed) up to 2.5 bar, hot galvanized and powder coated cladding

MODULE OPTIONS		
51900802	RL module - fast cooling	Fast cooling for liquids in open vessels, effective recooling through air flow ducts on the outside of the vessel, no additional on-site connections, no cooling water required
604790	FA module - exhaust air filtration	Air filtration with condensate sterilization, for all contaminated sterile goods, recommended for security level L1 (S1), required from security level L2 (S2) by surveillance authority
608787	ADI - Steam spent condenser	Condensate cooling with tap water, on-site water connection required
50103738	Set of castors with parking brake	For portable installation of freestanding units, 1 kit = 4 pieces

ACCESSORIES		
609520	Lifting hoist	For easy loading and unloading, stainless steel, stroke 900 mm, load capacity 40 kg
50091747	Wire basket round	(ØxH) 385x260 mm, stackable, max. 2 baskets per device
50110034	Wire basket round	(ØxH) 385x248 mm, stackable, max. 2 baskets per device, special size
50091196	Wire basket round, with drip tray round	(ØxH) 385x260 mm, stackable, tray height 50 mm, max. 2 baskets per device
50092106	Metal bucket round	(ØxH) 390x280 mm, stackable, max. 2 buckets per device
50095759	Metal bucket round, with rotating lid	(ØxH) 390x280 mm, not stackable, max. 1 bucket per device
50089353	Condensate collector	For waste steam and condensate, 20 litres, made of PE plastic, with stainless steel immersion tube and quick coupling as well as hose set
50107364	Magnetic stirrer	One stirring point, including stirring bar and external control unit, pressure-tight encapsulated, integrated in the sterilizer, max. 40 litres stirring volume

Art.No.	VARIOKLAV GreenLine 140 S 160 S 180 S	
608931	GreenLine 140 S	Steam Sterilizer floor model, basic unit, usable volume 140 litres, (ØxL) 500x700 mm, feed water volume 7 litres, MT module - media temperature control with flexible temperature probe, max. operating pressure -1 (vakuum fixed) up to 2.5 bar, hot galvanized and powder coated cladding
608943	GreenLine 160 S	Steam Sterilizer floor model, basic unit, usable volume 160 litres, (ØxL) 500x800 mm, feed water volume 7 litres, MT module - media temperature control with flexible temperature probe, max. operating pressure -1 (vakuum fixed) up to 2.5 bar, hot galvanized and powder coated cladding
608944	GreenLine 180 S	Steam Sterilizer floor model, basic unit, usable volume 180 litres, (ØxL) 500x900 mm, feed water volume 7 litres, MT module - media temperature control with flexible temperature probe, max. operating pressure -1 (vakuum fixed) up to 2.5 bar, hot galvanized and powder coated cladding

MODULE OPTIONS		
51900802	RL module - fast cooling	Fast cooling for liquids in open vessels, effective recooling through air flow ducts on the outside of the vessel, no additional on-site connections, no cooling water required
604790	FA module - exhaust air filtration	Air filtration with condensate sterilization, for all contaminated sterile goods, recommended for security level L1 (S1), required from security level L2 (S2) by surveillance authority
608787	ADI - Steam spent condenser	Condensate cooling with tap water, on-site water connection required
50103739	Set of castors with parking brake	For portable installation of freestanding units, 1 kit = 4 pieces

ACCESSORIES		
609367	Lifting hoist	For easy loading and unloading, stainless steel, stroke 900 mm, load capacity 40 kg
50091748	Wire basket round	(ØxH) 485x200 mm, stackable, max. 3 baskets per device
50099633	Wire basket round	(ØxH) 485x240 mm, stackable, max. 2 baskets per device, special size
50092114	Wire basket round	(ØxH) 485x320 mm, stackable, max. 2 baskets per device
50092112	Wire basket round, with drip tray round	(ØxH) 485x320 mm, stackable, tray height 50 mm, max. 2 baskets per device
50090683	Hanging tray for sterilization baskets	(Ø) 470 mm, including 4 mounting brackets for further loading level in the basket
50099824	Metal bucket round	(ØxH) 470x310 mm, stackable, max. 2 buckets per device
50095753	Metal bucket round, with rotating lid	(ØxH) 490x345 mm, not stackable, max. 1 bucket per device
50089353	Condensate collector	For waste steam and condensate, 20 litres, made of PE plastic, with stainless steel immersion tube and quick coupling as well as hose set
50107364	Magnetic stirrer	One stirring point, including stirring bar and external control unit, pressure-tight encapsulated, integrated in the sterilizer, max. 40 litres stirring volume



Art.No.	VARIOKLAV GreenLine 80 T	
608930	GreenLine 80 T	Steam Sterilizer tabletop model, basic unit, usable volume 80 litres, (ØxL) 400x625 mm, feed water volume 5 litres, MT module - media temperature control with flexible temperature probe, max. operating pressure -1 (vakuum fixed) up to 2.5 bar, hot galvanized and powder coated cladding

	MODULE OPTIONS	
51900802	RL module - fast cooling	Fast cooling for liquids in open vessels, effective recooling through air flow ducts on the outside of the vessel, no additional on-site connections, no cooling water required
604790	FA module - exhaust air filtration	Air filtration with condensate sterilization, for all contaminated sterile goods, recommended for security level L1 (S1), required from security level L2 (S2) by surveillance authority
608787	ADI - Steam spent condenser	Condensate cooling with tap water, on-site water connection required

	ACCESSORIES	
609328	Undercarriage 80 T	(BxHxT) 60x80x73 mm, with additional shelf, 2 casters on the back, stainless steel, max. load capacity 300 kg
50101326	Wire basket cubic	(WxHxD) 300x120x535 mm, stackable, max. 2 baskets per device
50085013	Metal tub cubic	(WxHxD) 290x80x535 mm, stackable, max. 2 tubs per device
50085020	Center shelf	(WxHxD) 360x15x580 mm, loading level height adjustable in four positions, stainless steel
50089353	Condensate collector	For waste steam and condensate, 20 litres, made of PE plastic, with stainless steel immersion tube and quick coupling as well as hose set

Art.No.	VARIOKLAV GreenLine 140 T 160 T 180 T	
608932	GreenLine 140 T	Steam Sterilizer tabletop model, basic unit, usable volume 140 litres, (ØxL) 500x725 mm, feed water volume 8 litres, MT module - media temperature control with flexible temperature probe, max. operating pressure -1 (vakuum fixed) up to 2.5 bar, hot galvanized and powder coated cladding
608946	GreenLine 160 T	Steam Sterilizer tabletop model, basic unit, usable volume 160 litres, (ØxL) 500x825 mm, feed water volume 10 litres, MT module - media temperature control with flexible temperature probe, max. operating pressure -1 (vakuum fixed) up to 2.5 bar, hot galvanized and powder coated cladding
608947	GreenLine 180 T	Steam Sterilizer tabletop model, basic unit, usable volume 180 litres, (ØxL) 500x925 mm, feed water volume 12 litres, MT module - media temperature control with flexible temperature probe, max. operating pressure -1 (vakuum fixed) up to 2.5 bar, hot galvanized and powder coated cladding

	MODULE OPTIONS	
51900802	RL module - fast cooling	Fast cooling for liquids in open vessels, effective recooling through air flow ducts on the outside of the vessel, no additional on-site connections, no cooling water required
604790	FA module - exhaust air filtration	Air filtration with condensate sterilization, for all contaminated sterile goods, recommended for security level L1 (S1), required from security level L2 (S2) by surveillance authority
608787	ADI - Steam spent condenser	Condensate cooling with tap water, on-site water connection required

	ACCESSORIES	
609329	Undercarriage 140 T	(WxHxD) 632x800x790 mm, with additional shelf, 2 casters on the back, stainless steel, max. load capacity 300 kg
609351	Undercarriage 160 T	(WxHxD) 632x800x890 mm, with additional shelf, 2 casters on the back, stainless steel, max. load capacity 300 kg
609352	Undercarriage 180 T	(WxHxD) 632x800x990 mm, with additional shelf, 2 casters on the back, stainless steel, max. load capacity 300 kg
50101327	Wire basket cubic	(WxHxD) 350x170x335 mm, stackable, 4 baskets per device
50101325	Metal tub cubic	(WxHxD) 350x80x335 mm, stackable, 4 tubs per device
50085021	Center shelf	(WxHxD) 360x15x580 mm, loading level height adjustable in four positions, stainless steel
50089353	Condensate collector	For waste steam and condensate, 20 litres, made of PE plastic, with stainless steel immersion tube and quick coupling as well as hose set

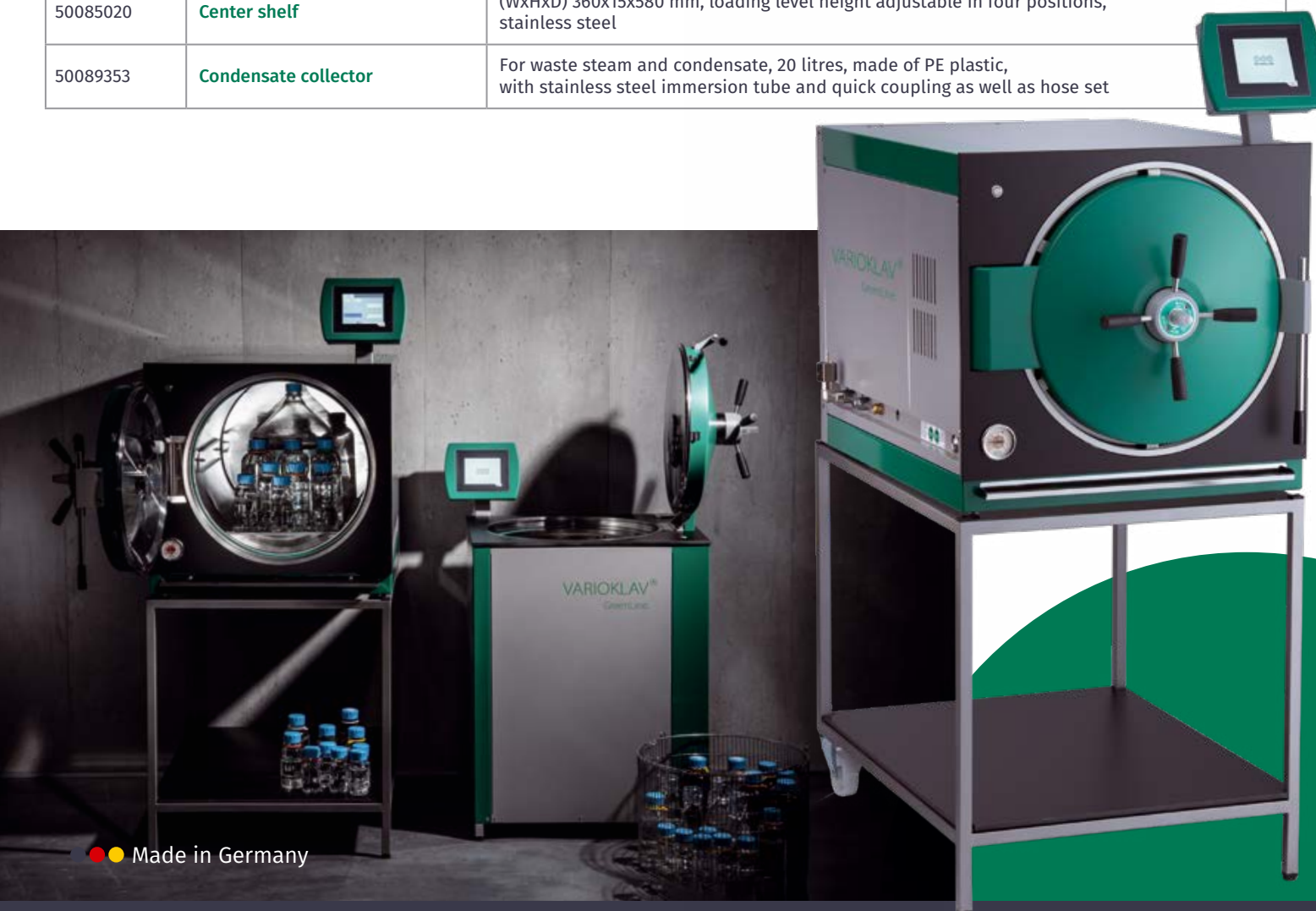

●●● Made in Germany

●●● Made in Germany

OrangeLine

Applications

In the fields of medicine and biology, reliable steamers are considered basic equipment for every laboratory.

They are used for heating, keeping warm and pressureless steaming of all kinds of growth media and are used for testing components, rubber goods and ceramics.

Control unit

The OrangeLine steamer can be operated unattended with no problems and will signal when the programme has been successfully completed by emitting a removal signal.

For unattended operation up to the withdrawal signal with continuously adjustable holding temperatures from 40° to 98 °C or fixed temperature at 98 °C.

Structure

- Steam chamber: square usable space, with stainless steel floor support, low loading height, very narrow design, space-saving dimensions.
- Lid: lateral impact prevents scalding by steam, lid inclination to the front allows condensate to drain to the lower edge of the lid.
- Stainless steel lid made of 1.4301 stainless steel



All advantages at a glance

- Robust and rustproof square steam chamber made of 1.4301 stainless steel
- Chamber volume 95 litres
- Relative humidity of between 10 and 100%
- Infinitely variable temperature setting between 40 and 98 degrees Celsius
- Low working heights starting at 750 millimetres for comfortable loading and unloading of the steam chamber
- Narrow and space-saving design – also suitable for smaller laboratories and practices
- Drainage of the condensate towards the edge of the cover
- No cooling water required for cooling the periphery
- Strategic ventilation in the lowest part of the chamber prevents the formation of air pockets
- In case of insufficient water, the steamer emits visual and audible malfunction signals
- Thermal lock in accordance with TRB 402 for fully automatic switching off of the heating system if there is a lack of water, thus preventing the base from overheating

Art.No.	VARIOKLAV OrangeLine 95 S	
51024987	OrangeLine 95 S	Steam pot, floor model, for warming, heating and pressureless steaming of nutrient media, usable volume 95 litres, 3,4 kW, heat holding temperature from 40 °C - 98 °C, incl. radial fan, media temperature control, condensate discharge program
	MODULE OPTIONS	
51901845	Automatic water supply	With level monitoring
	ACCESSORIES	
50091747	Wire basket round	(ØxH) 385x260 mm, stackable, max. 2 baskets per device
50107364	Magnetic stirrer	Magnetic stirrer with one stirring point, including stirring bar and external control unit, pressure-tight encapsulated, max. 40 litres stirring volume

Feed water and energy supply

Due to the special design of the radiators, only a feed water supply of less than 0.5 liters is required for each 1 kW of heating capacity. The filling quantity is approx. 8 liters.

This means that work can be carried out over a working day without refilling. Energy consumption for steaming is minimal, as only a small amount of heating power is switched on after the heating phase.

Radial fan inside the chamber

In the heating phase and during tempering, the steam-air mixture is swirled. This avoids different temperatures (hot at the top, cooler at the bottom). The heat transfer into the medium is improved, and the heating time is significantly reduced.

Heating and cooling

The chamber is heated electrically from the outside by means of contact heating elements. Rising steam heats the articles to be decontaminated. The floor is flat and easy to clean. Heating elements no longer come into contact with aggressive feed water.

The feed water needed to cover the heating surface is kept to a minimum. No cooling water needed for boundary cooling. Deaeration in the lowest part of the chamber prevents the forming of air pockets.

Dry run protection

The heated surface is equipped with a TÜV approved temperature monitor. In case of water shortage or before overheating of the floor the heating switches off automatically.

Overtemperature protection on each radiator prevents overloading of the heating system. With visual and acoustic malfunction indicator in case of water shortage.

●●● Made in Germany

VARIOKLAV MODULE

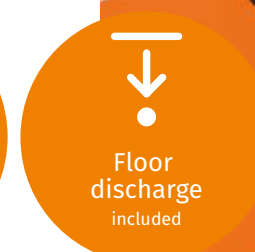
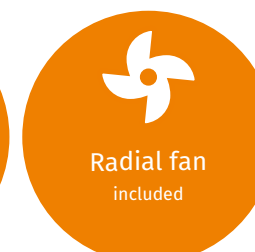
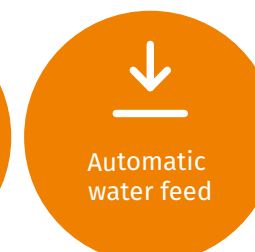
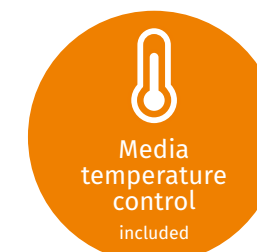

BlueLine free-standing units		75 S	100 S	135 S	155 S	175 S
Usable volume	l	75	100	135	155	175
Usable dimensions (Ø/L)	mm	400/600	400/800	500/700	500/800	500/900
Outer dimensions (W/D/H)	mm	500/650/1000	500/650/1200	600/750/1050	600/750/1150	600/750/1250
Weight of basic unit	kg	140	160	170	190	210
Operating temperature	°C	98° - 135° optional 140°				
Max. operating overpressure/vacuum	bar	4,0/-1				
Steam generator volume	l	6,0		8,0		
Housing		powder-coated				
Heating capacity	kW	4,5		7,5		
Article number		51024301	51902900	51024302	51902901	51902902

BlueLine table-top units		65 T	75 T	100 T	135 T	155 T	175 T	195 T
Usable volume	l	65	75	100	135	155	175	195
Usable dimensions (Ø/L)	mm	330/630	400/600	400/800	500/700	500/800	500/900	500/1.000
Outer dimensions (W/D/H)	mm	520/700/850	540/810/780	540/1.010/780	640/890/880	640/990/880	640/1.090/880	640/1.190/880
Weight of basic unit	kg	150	150	170	180	205	210	220
Operating temperature	°C	134°	98° - 135° optional 140°					
Max. operating overpressure/vacuum	bar	3/-1	4,0/-1					
Steam generator volume	l	6,4	6,4	6,4	8,2	8,2	8,2	8,2
Housing		powder-coated						
Heating capacity	kW	6,4	4,5	4,5	7,5	7,5	7,5	7,5
Article number		51024307	51024303	51902903	51024304	51902904	51902905	51902906

OrangeLine free-standing units		95 S
Temperature	°C	40° - 98°
External dimensions (W/H/D)	mm	500/800/620
Loading height	mm	750
Usable space dimensions	mm	400/400
Usable depth	mm	600
usable volume	Liter	95
Connected load	kW	3,4
Voltage / Frequency	V/Hz	230 / 50
Article number		51024987

GreenLine free-standing units		80 S	140 S	160 S	180 S
Usable volume	l	75	140	160	180
Feed water volume	l	5	7	7	7
Usable dimensions (Ø/L)	mm	400/600	500/700	500/800	500/900
External dimensions (W/D/H)	mm	600/500/1030	700/600/1130	700/600/1230	700/600/1330
Weight of basic unit	kg	120	160	170	180
Operating temperature	°C	98° - 134°			
Operating overpressure	bar	2,5			
Heat output	kW	3,0	6,0		
Power consumption	kW	3,2	6,2		
Heat dissipation to environment	%	8 - 15 % (% of heat output)			
Design		DIN EN 58951-2			
Protection class		1			
Mains connection		~ 230 V	3N~400 V		
Frequency		50 Hz			
Standards		IP 22			
Article number		608379	608931	608943	608944

GreenLine table-top units		80 T	140 T	160 T	180 T
Usable volume	l	72	136	154	172
Feed water volume	l	5	8	10	12
Usable dimensions (Ø/L)	mm	400/625	500/725	500/825	500/925
External dimensions (W/D/H)	mm	600/800/580	700/900/680	700/1000/680	700/1100/680
Weight of basic unit	kg	120	160	170	180
Operating temperature	°C	98° - 134°			
Operating overpressure	bar	2,5			
Heat output	kW	5,0	6,0		
Power consumption	kW	5,2	6,2		
Heat dissipation to environment	%	8 - 15 % (% of heat output)			
Design		DIN EN 58951-2			
Protection class		1			
Mains connection		3N~400 V			
Frequency		50 Hz			
Standards		IP 22			
Article number		608930	608932	608946	608947

Type	Useful volume (l)	Laboratory flasks					Erlenmeyer-flask (1.000 ml)	Waste Solids (kg)
		Round (500 ml)	Round (1.000 ml)	Round (2.000 ml)	Square (250 ml)	Square (500 ml)		
BlueLine free-standing unit								
BlueLine 75 S	75	45	18	10	80	28	10	≥ 25
BlueLine 100 S	100	60	27	10	100	36	15	≥ 30
BlueLine 135 S	135	66	45	16	140	66	24	≥ 30
BlueLine 155 S	155	66	45	16	140	66	24	≥ 30
BlueLine 175 S	175	≥ 66	≥ 45	≥ 16	≥ 140	≥ 66	≥ 24	≥ 30
BlueLine table-top unit								
BlueLine 25 T	25	6	4	-	14	12	3	≥ 5
BlueLine 65 T	65	21	18	8	90	24	8 - 10	≥ 30
BlueLine 75 T	75	28	15	8	72	28	8 - 12	≥ 25
BlueLine 100 T	100	28	15	8	72	28		≥ 30
BlueLine 135 T	135	64	27	10	100	64	15	≥ 30
BlueLine 155 T	155	64	27	10	100	64	18	≥ 30
BlueLine 175 T	175	≥ 64	≥ 27	≥ 10	≥ 100	≥ 64	21	≥ 30
BlueLine 195 T	195	≥ 64	≥ 27	≥ 10	≥ 100	≥ 64	24	≥ 30

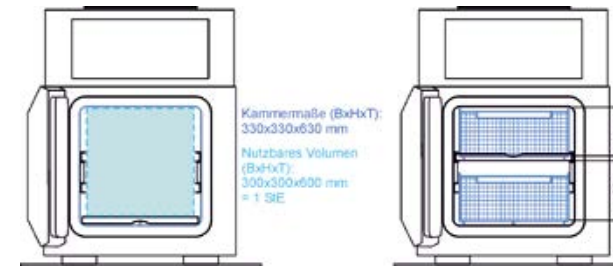

BlueLine 65 T: Use of mesh insert baskets, cubic [mm]

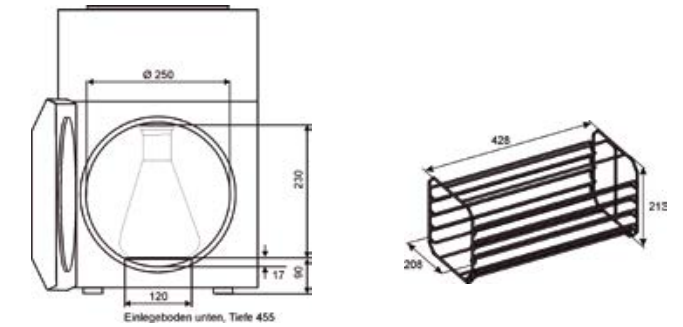

BlueLine 25 T: Capacity (left) and chamber insertion system (right)

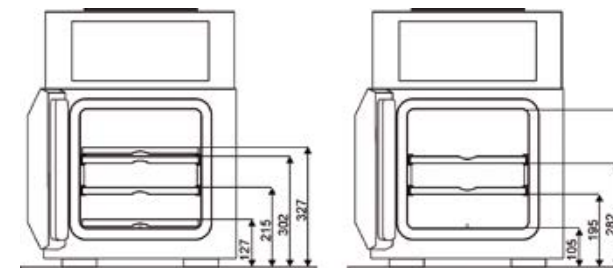

BlueLine 65 T: Loading heights [mm], various insertion options for the shelves

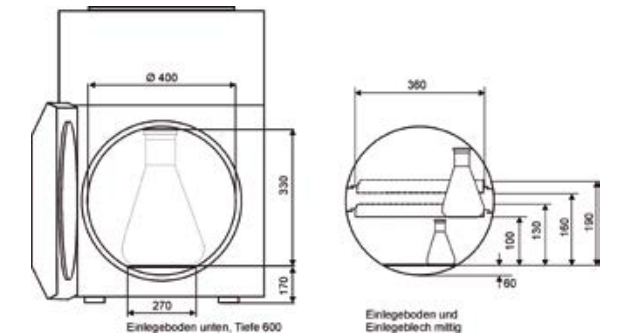

BlueLine 75 T: Loading heights [mm], four insertion options for central insert tray

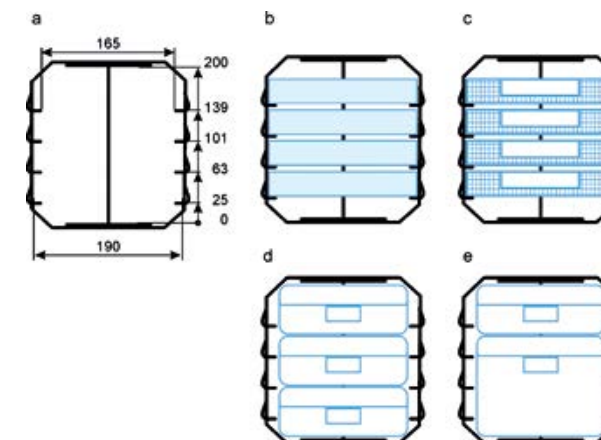

BlueLine 25 TV: Chamber insertion system
 a: rail heights [mm],
 b: with up to 4 insert trays (190/425/30 mm)
 c: with up to 4 wire mesh trays (186/425/30 mm)
 d: with up to 3 flat sterilization containers (162/425/60 mm)
 e: with one medium-height (162/425/120 mm) and one shallow and one flat sterilization load container (162/425/60 mm)

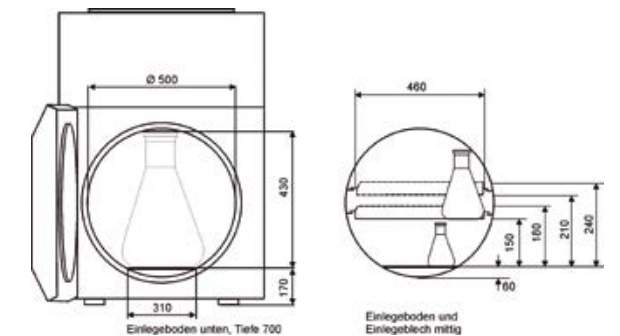

BlueLine 135 T: Loading heights [mm], four insertion options for central shelf

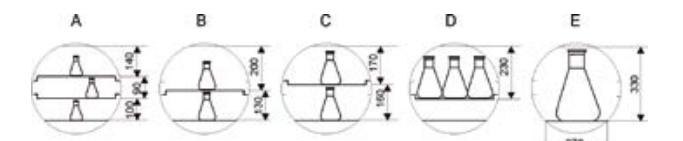

BlueLine 75 T: Loading heights [mm], various loading schemes

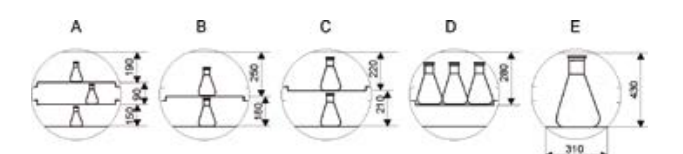

BlueLine type 135 T: Loading heights [mm], various loading schemes

Baskets and insert trays for table-top devices		
50101326	Wire basket cubic	(BxHxT) 300x120x535 mm, stackable, max. 2 baskets per unit possible
50101323	Metal tub cubic	(BxHxT) 290x80x535 mm, stackable, max. 2 tubs per unit possible
50101327	Wire basket cubic	(BxHxT) 345x170x335 mm, stackable, max. 4 baskets per unit possible
50101325	Metal tub cubic	(BxHxT) 350x80x335 mm, stackable, max. 4 tubs per unit possible
50091319	Chamber insert tray	for BlueLine 25 T, incl. 1 insert tray, max. 4 Insert trays per unit
50090577	Metal tub, cubic	for BlueLine 25 T, (WxHxD) 190x30x425 mm, suitable for chamber insertion system article number 51900825, 3 pieces = 1 PU
609625	Vaporizing tray	18/10 for BlueLine 25 T
609626	Tray	with 2 handles 18/10 for BlueLine 25 T
609627	Instrument tray	with lid 18/10 for BlueLine 25 T



Baskets and insert trays for floor-standing units		
50091747	Wire basket round	(ØxH) 385x260 mm, stackable
50110034	Wire basket round	(ØxH) 385x248 mm, stackable, special size
50091196	Wire basket round, with drip tray	(ØxH) 385x260 mm, stackable, shell height 50 mm
50092106	Metal bucket round	(ØxH) 390x280 mm, stackable
50095759	Metal bucket round, with rotating lid	(ØxH) 390x280 mm, not stackable
50091748	Wire basket round,	(ØxH) 485x200 mm, stackable
50099633	Wire basket round	(ØxH) 485x240 mm, stackable, special size
50092112	Wire basket round, with drip tray round	(ØxH) 485x320 mm, stackable, shell height 50 mm
50092114	Wire basket round	(ØxH) 485x320 mm, stackable
50099824	Metal bucket round	(ØxH) 470x310 mm, stackable
50095753	Metal bucket round, with rotating lid	(ØxH) 490x345 mm, not stackable

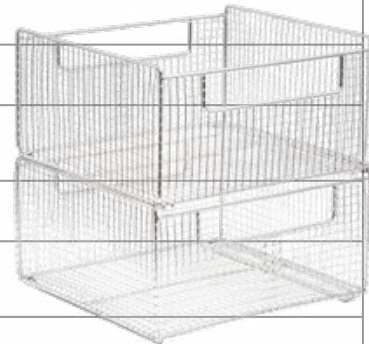

Insert systems and shelves		
50085024	Center shelf	For 65 T, stainless steel, electropolished, loading level adjustable in four positions
51900834	Center shelf	For 75 T 100 T, stainless steel, electropolished, loading level adjustable in four positions
51900835	Center shelf	For 135 T 155 T 175 T 195 T, stainless steel, electropolished, loading level adjustable in four positions
50085020	Center shelf	For 80 T, stainless steel, electropolished, loading level adjustable in four positions
50085021	Center shelf	For 140 T 160 T 180 T 200 T, stainless steel, electropolished, loading level adjustable in four positions
50090683	Suspension device	For mesh insert baskets (Ø) 470 mm, four fastening brackets for additional level in the basket

Loading trolley		
50095735	Loading trolley	for table-top units

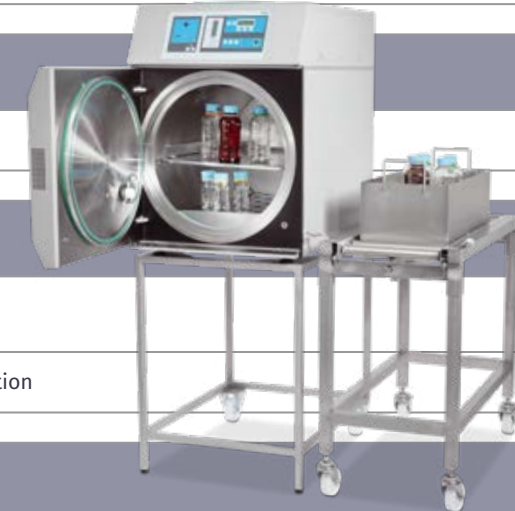

Desalination cartridge		
50094348	Desalination cartridge	For water desalination, type 2800, with conductivity meter and hose set
50094349	Desalination cartridge	Replacement cartridge for alternating operation

Compressor		
50095723	Air compressor	240V/50Hz, oil-free, for BlueLine module RG without on-site compressed air connection

Lifts		
50095875	Lift BlueLine	for 75 S, for easy loading and unloading, powder coated, stroke 900 mm, max. load capacity 40 kg
50095876	Lift BlueLine	for 150 S 155 S 175 S, for easy loading and unloading, powder coated, stroke 900 mm, max. load capacity 40 kg
609520	Lift GreenLine	for 80 S, for easy loading and unloading, powder coated, stroke 900 mm, max. load capacity 40 kg
609367	Lift GreenLine	for 140 S 160 S 180 S, for easy loading and unloading, powder coated, stroke 900 mm, max. load capacity 40 kg

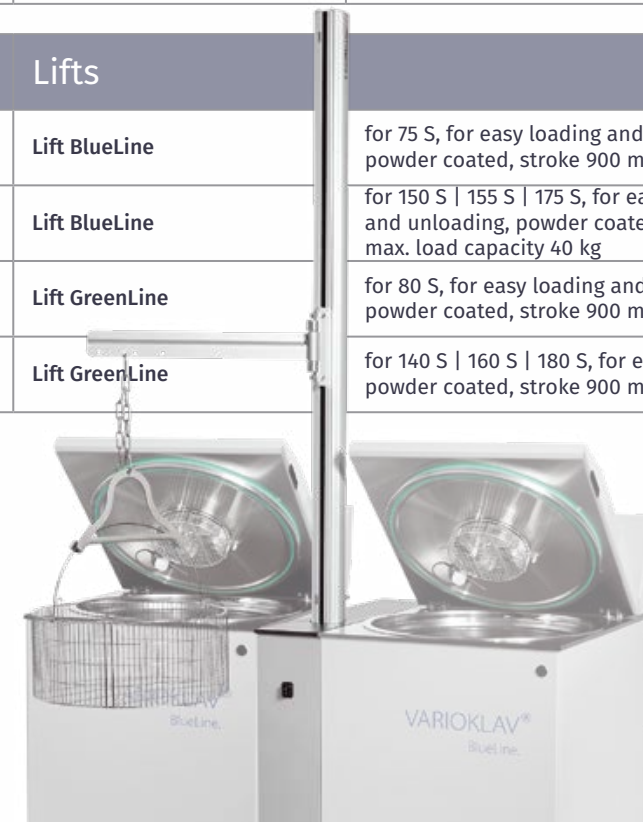

Art.No. Flasks		
609761	DURAN YOUTILITY Flask	GL45, clear, screw cap, pouring ring and bottle tag, 1,000 ml

Art.No. Autoclave Deodorant		
6318004	Autoclave Deodorant Anabac	Natural Coconut, PU =50
6318005	Autoclave Deodorant Anabac	Natural Vanilla, PU =50
6318006	Autoclave Deodorant Anabac	Natural Mimosa, PU =50
6228599	Autoclave Deodorant Anabac	Classic, based on eucalyptus extracts, PU =100
6231161	Autoclave Deodorant Anabac	Poma, based on apple extract, PU =100
6231720	Autoclave Deodorant Anabac	Citrus, based on lemon extract, PU =100
7626766	Autoclave Deodorant Anabac	Peach, based on peach extract, PU =100
6313709	Autoclave Deodorant Anabac	Classic Berry, based on berry fruit, PU =100

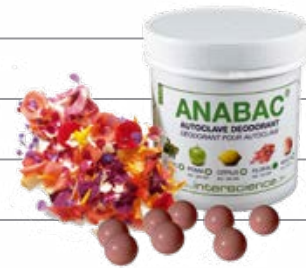

Art.No. Disposal bag		
6285813	LLG-Disposal bag	500x600 mm, PP, red, 50µm, with Biohazard imprint and sterile indicator, PU =200
6285814	LLG-Disposal bag	630x890 mm, PP, red, 50µm, with Biohazard imprint and sterile indicator, PU =200
6285815	LLG-Disposal bag	910x1150 mm, PP, red, 50µm, with Biohazard imprint and sterile indicator, PU =200

Art.No. Destruction bag		
9404099	LLG-Destruction bag	200x300mm, standard, PP, 50 µm, PU =100
9404221	LLG-Destruction bag	400x780mm, standard, PP, 50 µm, PU =250
9404222	LLG-Destruction bag	500x780mm, standard, PP, 50 µm, PU =250
9404224	LLG-Destruction bag	700x1100mm, standard, PP, 50 µm, PU =250
9404020	LLG-Destruction bag	200x300mm, highly transparent, PP, 50 µm, PU =100
9404100	LLG-Destruction bag	300x500mm, 6 l, highly transparent, PP, 50 µm, PU =500
9404101	LLG-Destruction bag	400x780mm, 22 l, highly transparent, PP, 50 µm, PU =500
9404102	LLG-Destruction bag	600x800mm, 32 l, highly transparent, PP, 50 µm, PU = 00
9404104	LLG-Destruction bag	700x1100mm, 72 l, highly transparent, PP, 50 µm, PU =350



Art.No. Sterilization tape		
9140783	Comply sterilization tape	For dry sterilization (hot air) 19 mm x 55 m
9140786	Comply indicator tape	For steam, lead-free indicator tape (steam), 18 mm x 55 m

Art.No. Indicators and indicator tape		
6089578	Attest biological indicators	For steam, PU =100
6272290	Bowie-Dick-Test,	4 kg, PU =48
6272291	Bowie-Dick-Test,	7 kg, PU =24
9140784	Indicator adhesive tape	With steam indicator self-adhesive, for steam sterilization, 19 mm wide, 50 m per roll
9140789	Indicator adhesive tape	With steam indicator self-adhesive, for hot air sterilization 25 mm wide, 50 m per roll
9140790	Indicator adhesive tape	With steam indicator strongly adhesive, well suited for non-woven, blue, 19 mm wide, 50 m per roll
9140791	Indicator adhesive tape	With steam indicator strongly adhesive, well suited for non-woven, blue, 25 mm wide, 50 m per roll



Art.No. Gloves		
9414660	Protective glove	K-Basic Extra 6658 ca.22-27 cm, Gr. 8, type 60179, Kevlar, yellow, pair
9414661	Protective glove	K-Basic Extra 6658 ca.22-27 cm, Gr. 10, type 60179, Kevlar, yellow, pair
9414662	Protective glove	K-Basic Extra 6658 ca.22-27 cm, Gr. 12, type 60179, Kevlar, yellow, pair
9005260	Heat protection gloves	Nomex without closure, knitted, with forearm cuff, pair
9005250	Heat protection gloves	Nomex without closure, knitted, normal, size 9/10, pair



FACTORY SERVICE.

Malfunctions are annoying. That's why it's important to us that problems with your autoclaves are repaired reliably and sustainably. Our repair service is fast, uncomplicated and conscientious. Regardless of whether the repair is carried out on site or at the HP plant, we keep the costs as low as possible for you.

Your advantages:

- Original: Repair only with original HP spare parts
- Like new: Optical reconditioning
- Tested: Electrothermal test run
- Transparent: Repair and test documented in service report

HP LAB ACADEMY.

- Product training for laboratory autoclaves
- Technical safety training for users of laboratory autoclaves
- Technical training for our laboratory autoclaves (not freely bookable)
- We offer all training modules in German and English

The trainings are conducted by our product experts at your site or in our training rooms in Oberschleissheim (Greater Munich area) and Rotgau (Greater Frankfurt area).

Our courses each consist of a theory and a practical part. Practical learning is important, for example, possible error scenarios are simulated on the machine and are to be corrected by the course participants with the help of the trainer.



VARIOKLAV®
SUPPORT



HP LAB®
ACADEMY

Fast help. Guaranteed.

Our promise

- Original spare parts for all units built up to 1981
- Certified for laboratory and medical use
- Many years of experience in the industry
- Prompt response times
- Delivery reliability and adherence to delivery dates
- Security and profitability
- Guarantee on new and replacement parts



OUR TRAINING MODULES

Individual customer or group courses on request

Quality and environmental policy

- We develop and produce products and services that always meet the needs and expectations of our customers.
- We ensure that we constantly develop our products, services and processes further.
- The motivation, enthusiasm and satisfaction of our employees is important to us.
- The continuous improvement of environmental protection is an important concern for us.
- We always keep in mind the fulfilment of the relevant legal requirements and binding obligations.



Delivery and commissioning

Delivery, incl. packaging, transport, installation, commissioning, instruction and installation inspection in accordance with the German Ordinance on Industrial Safety and Health by a competent person.

For installation and commissioning, the supply and disposal connections required on site must be available in accordance with our technical data sheets.

The German Ordinance on Industrial Safety and Health (Betriebssicherheitsverordnung) requires an installation inspection by a competent person prior to commissioning. The prices do not include the German statutory value-added tax. Subject to technical and price changes.



Article no.	Device types
DL320	VARIOKLAV OrangeLine 95 S
DL321	VARIOKLAV BlueLine 25 TV
DL322	VARIOKLAV GreenLine 80 S, 140 S, 160 S, 180 S, 80 T, 140 T, 160 T, 180 T
DL323	VARIOKLAV BlueLine 75 S, 100 S, 135 S, 155 S, 65 T, 75 T, 100 T, 135 T

Service readiness and service quality define us:

- Original spare parts for all appliances built up to 1981, optionally new or in exchange
- Certified for the laboratory sector
- Years of experience in the industry
- Factory service
- Intensively trained and authorised and authorised service technicians
- Prompt response times
- Delivery reliability and adherence to schedules
- Customer satisfaction after every technical assignment
- Security and profitability
- Warranty on new and replacement parts

Standards and laws

VARIOKLAV Steam sterilizers are equipped and tested in accordance with the requirements of the Pressure Equipment Directive DGRL 2014/68/EU for stationary and mobile operation.

Monitoring is carried out in cooperation with a notified body. The safety equipment of VARIOKLAV Steam sterilizers is already tested at the factory. This simplifies installation and commissioning on site.

Our service technicians are qualified persons in the sense of the Ordinance on Industrial Safety and Health (BetrSichV). When commissioning is ordered by HP, the requirements of the Ordinance on Industrial Safety and Health (BetrSichV) and the trade supervisory authorities are fulfilled.



HP LAB[®]
QUALITY

Warranty

- 1 year on material and manufacturing defects
- 3 years on heaters
- 5 years on pressure vessels

Customer satisfaction survey

In September 2020, the satisfaction with our factory customer service was determined within the scope of a survey of approx. 100 maintenance contract customers. with our factory customer service.

VARIOKLAV[®]
EXCELLENCE IN AUTOCLAVES

How can we help you? We will be happy to advise you!

Select base unit

Floor-standing or table-top unit?

In floor-standing appliances, the chamber volume is utilised to the maximum with basket heights that are matched to the bottle size.

Table-top units are easier to load and unload, can also be loaded without a basket and require a solid table or base frame as a support.

Define field of application

Our basic units are already equipped for the usual laboratory tasks. Liquids and culture media are usually autoclaved at 121 °C and solids at 134 °C. This meets the requirements of most fields of work.

If production processes need to be monitored, the sterilization data is recorded in a traceable manner via a built-in batch printer or by means of software.

For biological and genetically modified agents or infectious germs from the clinical area, classifications are defined according to the existing risks. If necessary, clarify the classification of your laboratory and the requirements with the responsible supervisory authority.

Select module options

The VARIOKLAV Steam sterilizers can be equipped with numerous module options:

Choose between modules for cooling and fast recooling, pre-vacuum and vacuum drying, emission-free sterilization, process documentation and media temperature control to optimally adapt your autoclave to your routine work.

Book special services

Transport, installation, commissioning, instruction and installation testing in accordance with the „Ordinance on Industrial Safety and Health“ by a competent person, operational qualification and validation of defined processes, all these services can be offered in-house.

Select chamber volume

Which chamber volume is required?
Which setting range is available?

The models are manufactured in different sizes. There are chamber volumes from 25 to 200 litres. On request, we can supply identically constructed units with extended usable chambers.

Determine specific processes

How often and what, with what quality requirements do you sterilize?

With a few exceptions, the two modules for rapid cooling and the two vacuum processes, pre-vacuum for air removal and post-vacuum for drying, can cover all standard laboratory applications. Sterilization processes for liquids in open and pressure-tight sealed vessels as well as for solids and porous materials (consumables) are thus carried out quickly and with high quality.

If potentially risky substances are to be handled, the respective normative requirements or regulations must be met. The module for exhaust air filtration with condensate sterilization in combination with the module for data recording (traceability of the sterilization process) ensures validatable, safe operation in such cases.

Extend expansion stages

On request
In the highest protection class 4 or safety level 4, additional measures are to be provided for particularly risky sterilized goods.

Additional processes are available for special sterilization tasks, e.g. for Durham tubes. Sterilization temperatures above 134 °C are also available. Processes without a preceding deaeration phase are particularly suitable for steam/air mixtures.

Stirring in large volumes of liquid.
For culture media in vessels of 5 litres or more, stirring is recommended throughout the sterilization process. Continuous circulation of the liquid with a stirring system prevents the build-up of a temperature gradient - hot at the top and cold at the bottom - in the medium and minimises the high thermal load in the upper layers.

Please offer us the following unit configuration::

Areas of application::

- Microbiology laboratory/nutrient media
- Clinical laboratory operations/infectious
- Pressure chamber
- Biological agents
- Pharmaceutical products
- Other (please specify)
- Genetically modified agents
- Sterilizability testing

We sterilize liquids:

- Liquids in open vessels
- Liquids/creams in plastic bags
- Liquids in pressure-tight sealed vessels
- Other (please specify)
- Liquids Solutions, nutrient media, lightly sealed
- Liquids in sealed vessels (blood bags or similar)
- Sensitive media
- Vessel size ml

We sterilize waste:

- Filters
- Infusion bottles
- Other (please specify)
- Pipette tips
- Waste in open bags
- Instruments
- Waste in closed bags
- Glasware
- Ampoules

We sterilize textiles and consumables:

- Laundry, textiles
- Other (please specify)
- Highly infectious materials
- Destruction sterilization of consumables

The usable space:

- 25 Litres
- 75 Litres
- 100 Litres
- 140 Litres
- 155 Litres
- 180 Litres
- 200 Litres

The installation takes place:

- in the laboratory
- on the floor
- in the safety laboratory
- on the table
- in the scullery

The unit is expected to run:

- once a week
- 1 to 2 times daily
- 3 to 5 times a day
- additionally overnight/before work

We want our batches:

- documented
- Printer/recorder
- according to DIN 58950, FDA, etc.
- Software documentation

Heating takes place:

- electrically
- Sterile steam
- House steam

Modules and extensions:

- Media temperature control
- Emission-free sterilization
- Cooling and rapid cooling
- Process documentation
- Pre-vacuum and drying

If our application changes, our unit should be retrofittable in any case:

- be retrofittable and future-proof

What is the cost of:

- Maintenance contract
- VARIOKLAV CARE
- VARIOKLAV CARE PLUS

VARIOKLAV®

EXCELLENCE IN AUTOCLAVES

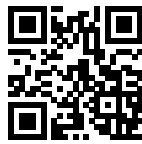

Visit us in the internet: www.hp-lab.com



Angelika Brunner

Sales

Phone +49 89 30 666 47-50
Mobile +49 151 624 256 23
Fax +49 89 30 666 47-59
angelika.brunner@hp-lab.com

HP Labortechnik GmbH

Bruckmannring 19
85764 Oberschleißheim
Deutschland

Phone +49 (89) 30 666 47 -0
Fax +49 (89) 30 666 47 -20

www.hp-lab.com
info@hp-lab.com